

O3G 2010 (EN 81-20/50)

MAIN FEATURES



Nominal load:	630 kg 8 Passengers
Speed:	1 m/s
Travel:	6,75 m
N. of stops:	3
Nº of acceses:	3
Lighting power:	230 V
Grid voltage:	415 V
N. of phases:	3 PHASES + NEUTRAL
Frequency:	50 Hz
Machine power:	4,5 kW
Heat rejected:	0,4 kW
Power grid supply:	5,3 kW
Nom. Current grid:	8,26 A
Max. Current grid:	9,52 A
Controller type:	COLEC-SELEC SIMPLEX
Deadweight car+frame:	533 kg
Number of ropes :	5
%Counterweighed:	45 %

LOADS IN DaN

P1: ±3270 daN	P8: ± - daN
P2: ±2330 daN	P9: ± - daN
P3: ±450 daN	P10: ± - daN
P4: ±1465 daN	P11: ± daN
P5: ± - daN	P12: ± daN
P6: ± - daN	P13: ± daN
P7: ± - daN	P14: ± daN

RANGING MEASURES MRL

A: 386 mm	F: 1589 mm
B: 111 mm	G: mm
C: 1589 mm	H: mm
D: 111 mm	I: mm
E: 276 mm	

A	LOP SITUATION - WALL	01/08/2017	AAA
EDITION	MODIFICATION	DATE	SIGNATURE
CUSTOMER: W STIRLAND LIMITED			
ADDRESS: CHICHESTER			
CITY: CHICHESTER-		REF: XGB62426LR	
	DRAWN	01/08/2017 AARANBURUA	SCALE
	CHECKED		UNIT mm
		DRAWING Nº	
		N401247A	
		PAGE	1 / 9

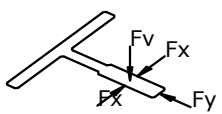
	CAR GUIDE	COUNTERWEIGHT GUIDE	
Guide type	T-127-L1/A	T-50/A	
Clip type	M2	SL1	
MAX DISTANCE BETWEEN BRACKETS [mm]	3130	3500	
Fx max [daN]	312,45	7,17	
Fy max [daN]	128,25	18,31	
Fv max [daN]	1267,61	38,23	
σ perm [N/mm ²]	261,11	125,33	
σ max [N/mm ²]	176,54	69,97	
δ perm [mm]	5	10	
δ guide max X [mm]	4,99	4,14	
δ guide max Y [mm]	4,85	4,94	
δ str max [mm]	0	0	

* Information about guides and flanges available on Orona's web 'Documentation per OV'

REMARKS

- All the conditions in the document 'Work preparation guide' must be followed

CUSTOMER: W STIRLAND LIMITED
ADDRESS: CHICHESTER
CITY: CHICHESTER-



DRAWN 01/08/2017
AARANBURUA

SCALE

DRAWING N°

N401247A

CHECKED

UNIT

mm

PAGE

2 / 9

REF:

XGB62426LR

2

1

0

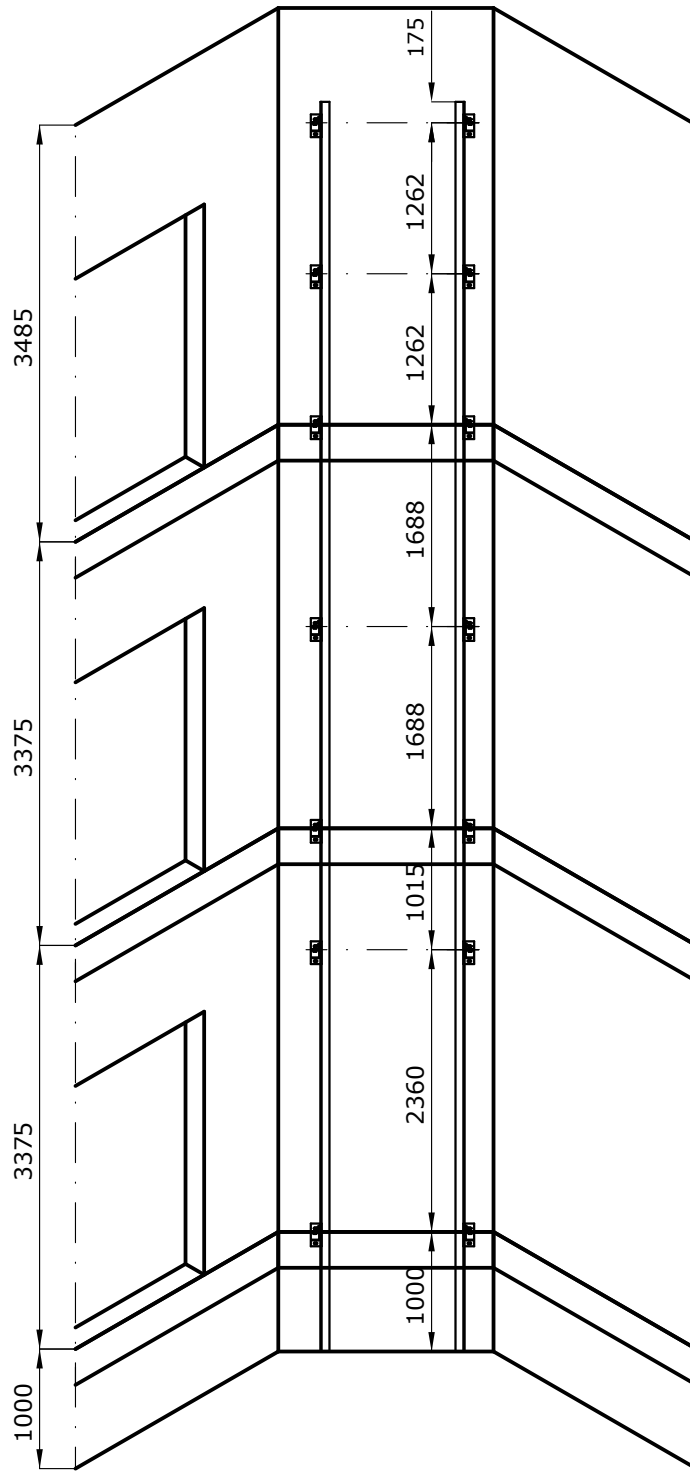

TRAVEL HEIGHT = 6750 mm
 NUMBER OF BRACKETS = 7
 MAX DISTANCE BETWEEN BRACKETS = 3130 mm
 NUMBER OF 5 m CAR'S COMPLETE RAILS = 2
 DISTANCE BETWEEN 1ST AND 2ND BRACKET >= 2360 mm
 2 STRETCHES OF 2.5 m
 AND TWO STRETCHES OF 2.95 m
 NUMBER OF 5 m C.W.'S COMPLETE RAILS = 2
 2 STRETCHES OF 2.5 m
 AND TWO STRETCHES OF 2.95 m

CUSTOMER: W STIRLAND LIMITED
 ADDRESS: CHICHESTER
 CITY: CHICHESTER-



DRAWN 01/08/2017
 AARANBURUA

SCALE

DRAWING N°

N401247A

CHECKED

UNIT

mm

PAGE

3 / 9

REF:

XGB62426LR

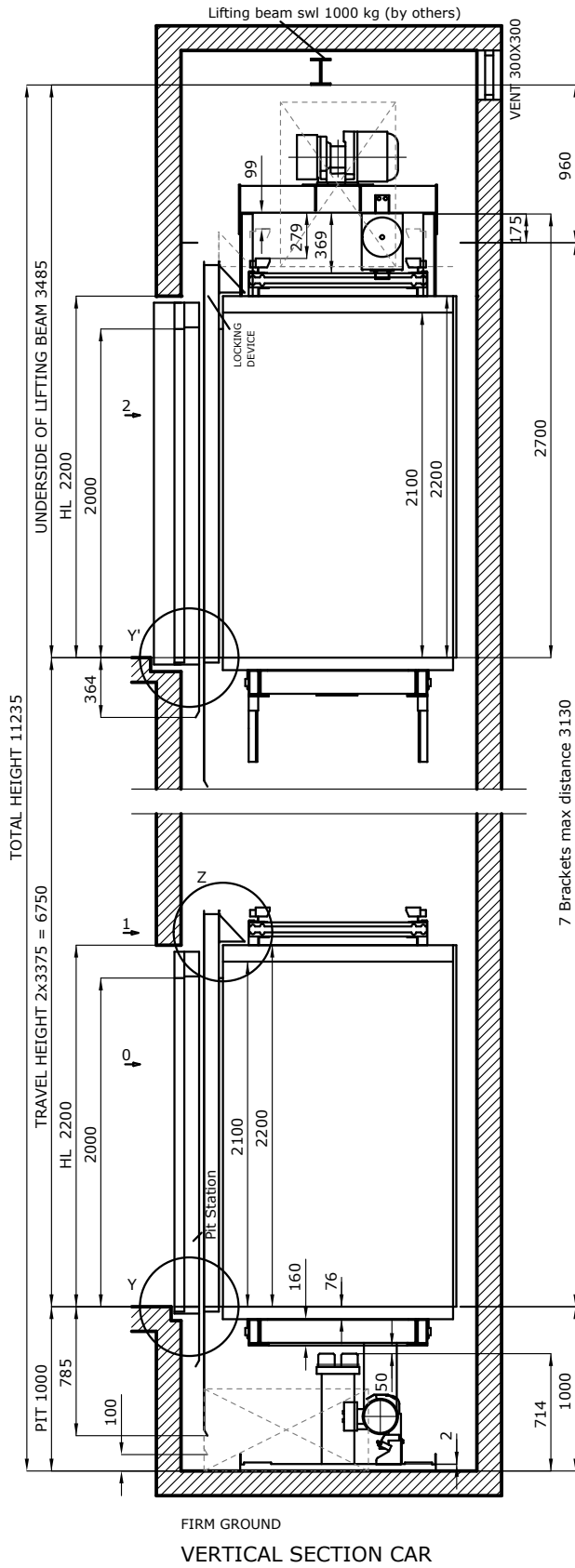

DOOR OPERATOR DETAIL Z

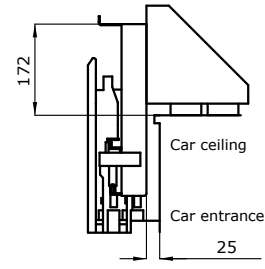

Y' DETAIL

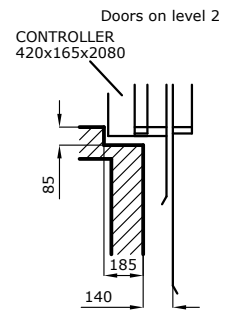

Y DETAIL

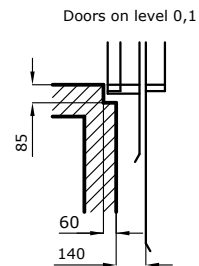

DRAWING NO
N401247A

SCALE
UNIT
mm

DRAWN
01/08/2017
AARIBBURUA

CHECKED

PAGE
4 / 9

REF:
XGB62426LR

CUSTOMER:
W STIRLAND LIMITED
ADDRESS:
CHICHESTER
CITY:
CHICHESTER-



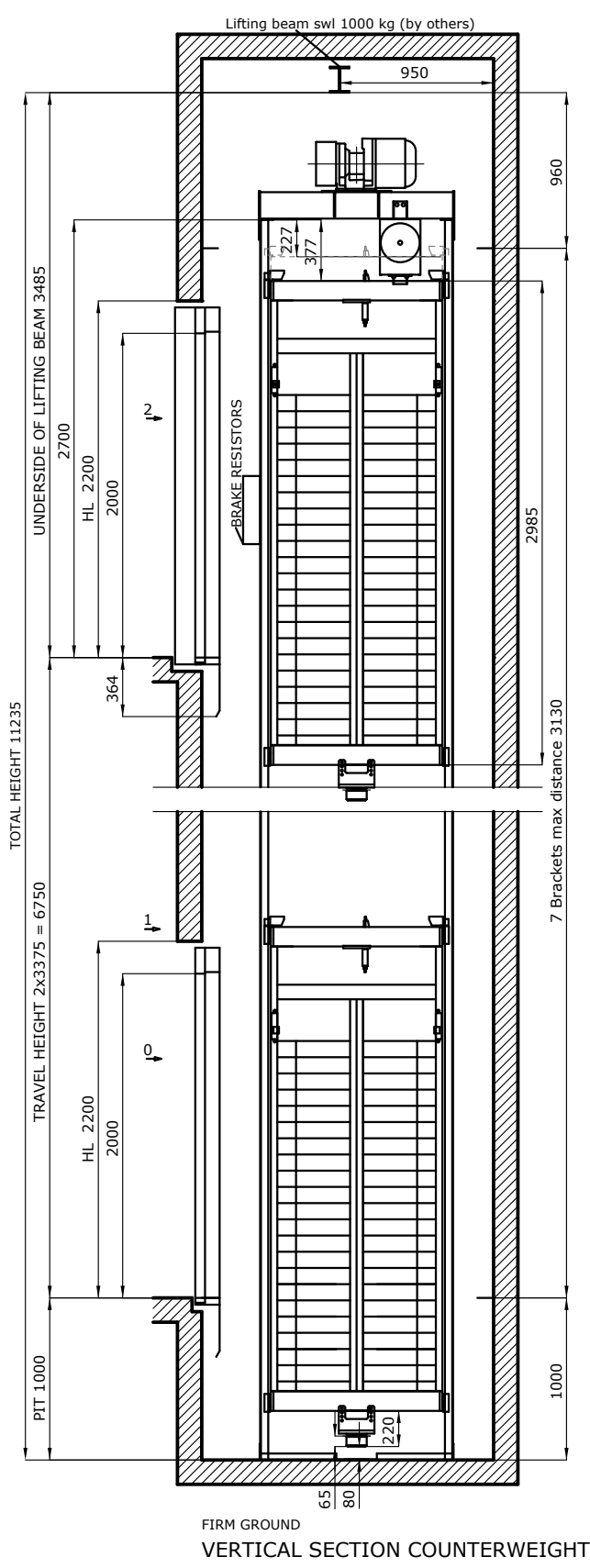

FIRM GROUND
 VERTICAL SECTION COUNTERWEIGHT

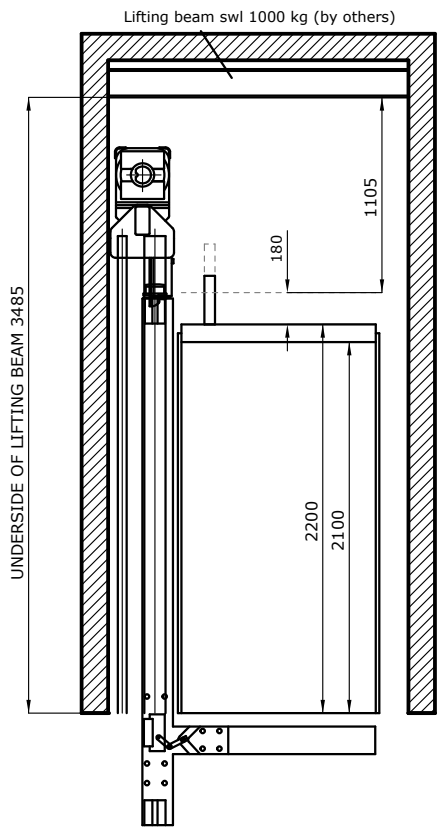

	CUSTOMER: W STIRLAND LIMITED ADDRESS: CHICHESTER CITY: CHICHESTER-		DRAWING NO N401247A	SCALE 01/08/2017 A4/08/08/04	UNIT mm	REF: XGB62426LR

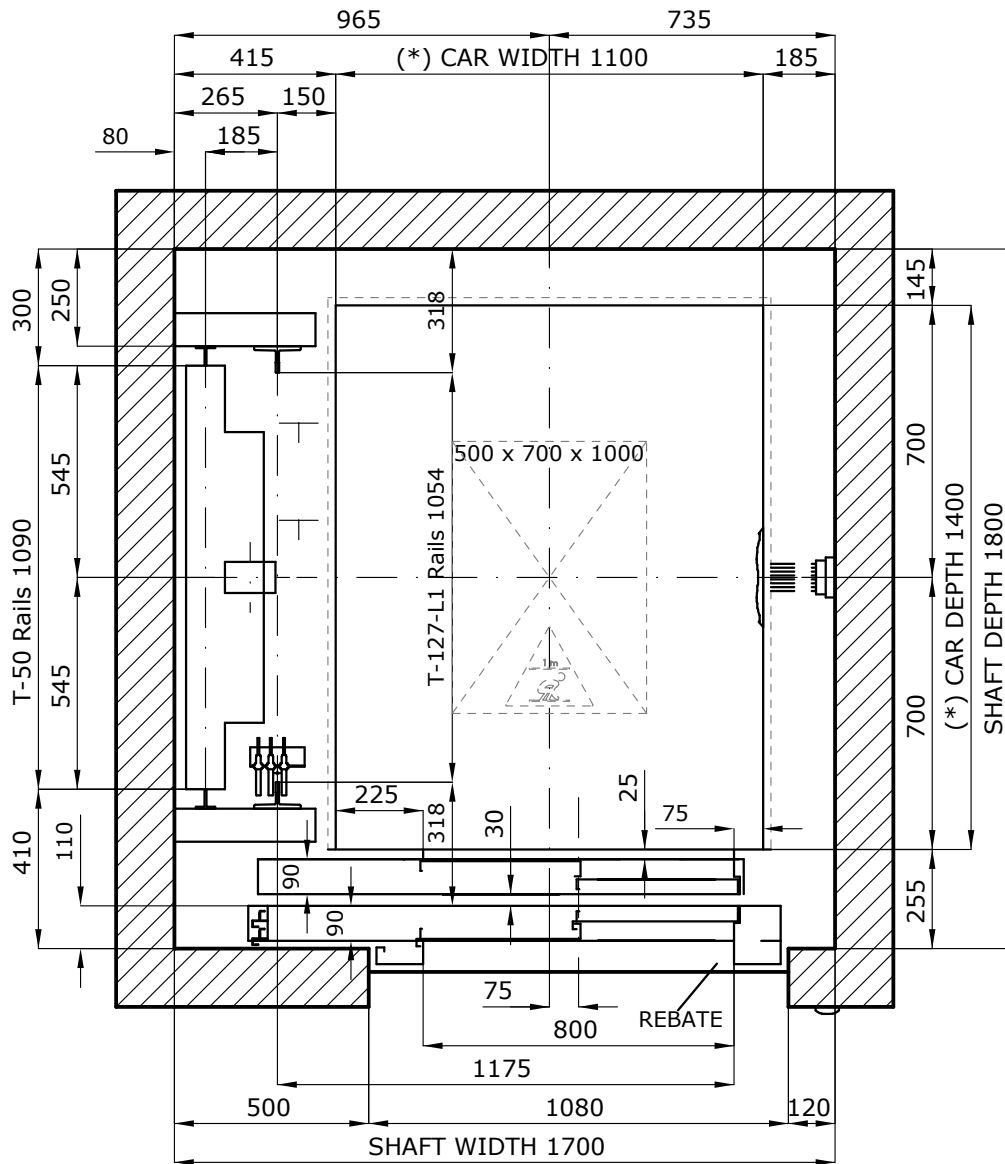

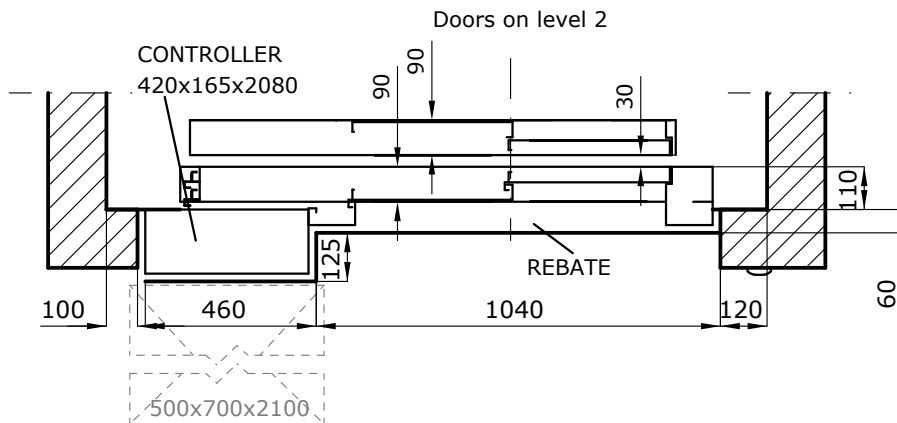

Doors on level 0,1

SHAFT PLAN
 Scale 1/20



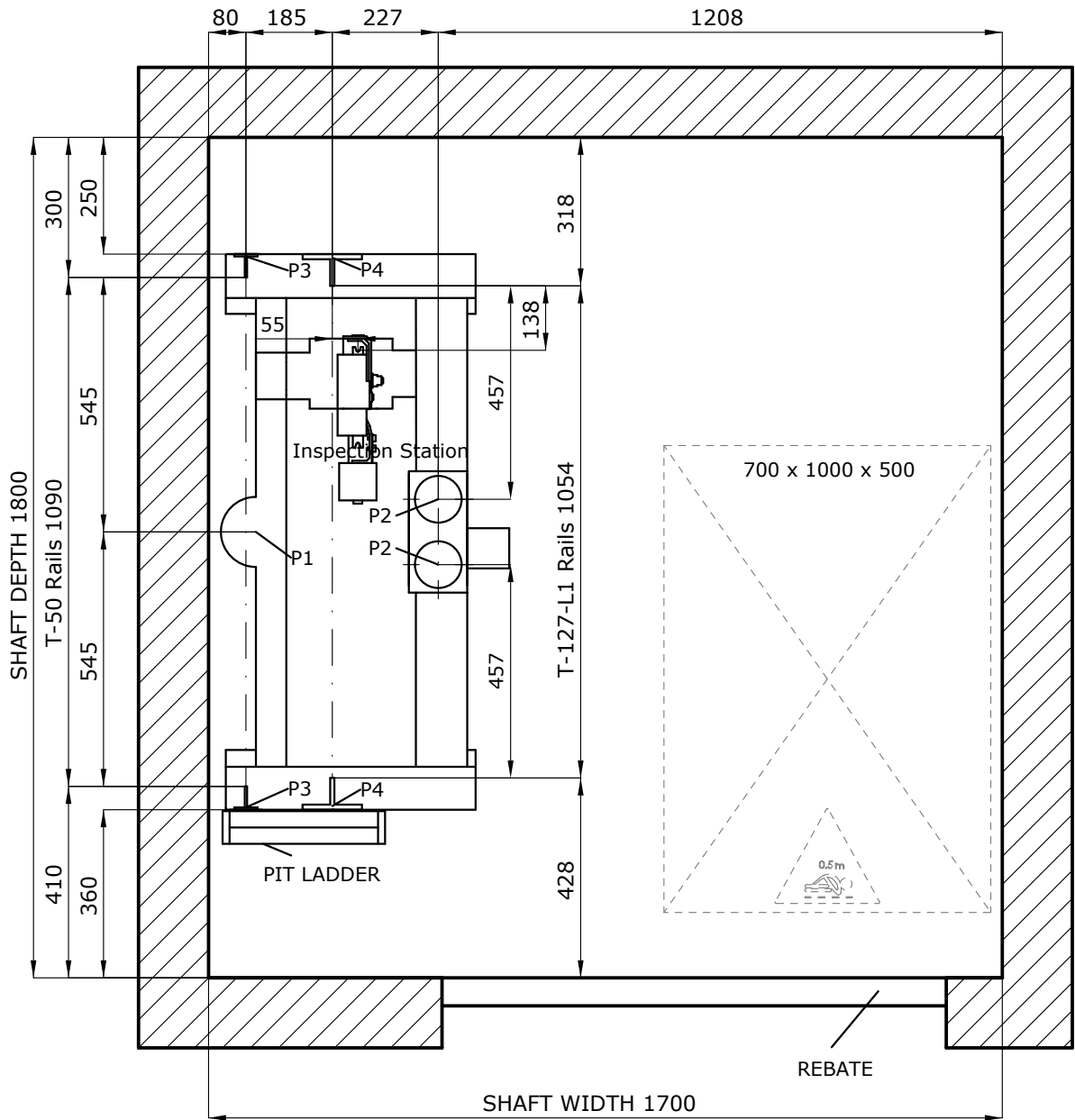

(*) Car dimensions according to EN81-70

CUSTOMER: W STIRLAND LIMITED ADDRESS: CHICHESTER CITY: CHICHESTER-		 REF: XGB62426LR	
	DRAWN 01/08/2017 AARANBURUA		



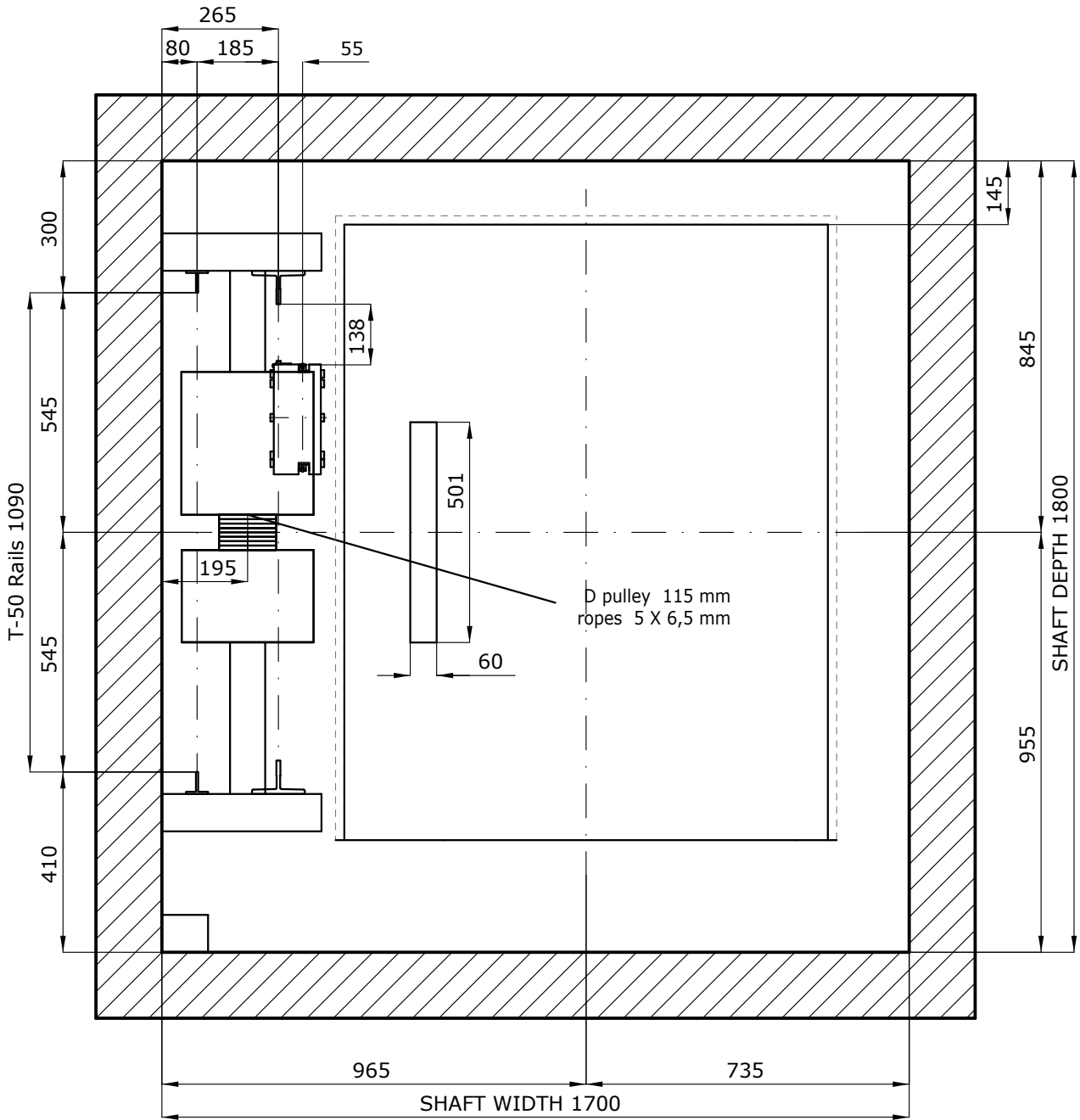

PLAN ON PIT
Scale 1/15

CUSTOMER: W STIRLAND LIMITED				
ADDRESS: CHICHESTER				
CITY: CHICHESTER-				
	DRAWN	01/08/2017 AARANBURUA	SCALE	DRAWING N° N401247A
	CHECKED		UNIT	PAGE
			mm	7 / 9
REF:				XGB62426LR



MACHINE VIEW
Scale 1/15

CUSTOMER: W STIRLAND LIMITED ADDRESS: CHICHESTER CITY: CHICHESTER-				
	DRAWN: 01/08/2017 AARANBURUA	SCALE:		
	CHECKED:	UNIT: mm	PAGE: 8 / 9	REF: XGB62426LR

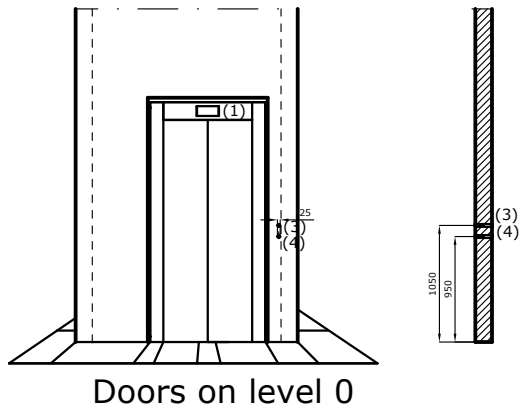
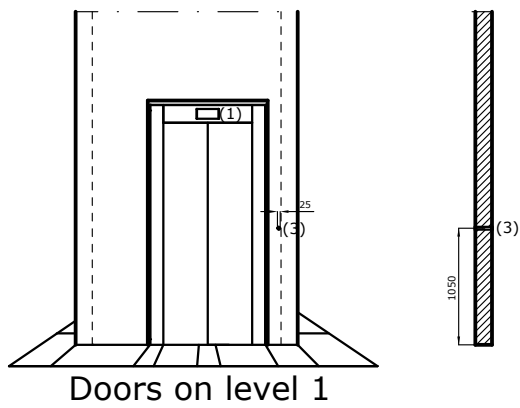
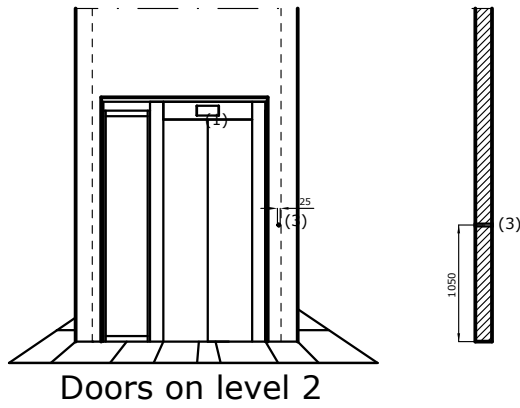

- (1) Indicator
- (3) LOP
- (4) EN81-73 (Evacuation) / Out of Service / EN81-70 / EN81-72

CUSTOMER: W STIRLAND LIMITED
 ADDRESS: CHICHESTER
 CITY: CHICHESTER-



Orona 	DRAWN	01/08/2017 AARANBURUA	SCALE	DRAWING N° N401247A
	CHECKED		UNIT mm	PAGE 9 / 9

REF: XGB62426LR